



Magnetic Power Systems, Inc.

1626 Manufacturers Drive. Fenton, MO 63026

Tel: 636.343.5550 | Fax: 636.326.0608 | magpowr@magpowr.com

Instruction Manual

Cygnus Web Tension Control Software Update Procedure

Introduction

The Cygnus software can be updated, using a PC compatible computer running any version of Windows® 95 or higher. The only special cabling is an adapter to connect the Cygnus to a standard RS-232 serial port. This adapter cable may be purchase directly from MAGPOWR.

Required Items

Option 1 (Update via E-mail or Website Download)

1. PC with 1 free serial port with Windows® 95 or higher operating system (400 MHZ minimum processor speed)
2. RS-232 Cable. 9-pin male to female straight cable (can be purchased locally).
3. HEXLOAD PC Communications software (Sent via e-mail or downloaded from the Magpowr website www.magpowr.com)
4. CYGNUS firmware (Sent via e-mail or downloaded from the Magpowr website www.magpowr.com)

Option 2 (Update via Magpowr Software Upgrade Kit)

1. PC with 1 free serial port with Windows® 95 or higher operating system (400 MHZ minimum processor speed.)
2. Magpowr Software Upgrade Kit P/N:
 - 9-pin male to female straight cable
 - CD with HEXLOAD PC Communications software and CYGNUS firmware

PC Software Installation

The HEXLOAD PC software does not require installation. Simply copy the program to any folder and start the program by double clicking its icon. The program does not require any external DLL files or run-time libraries to run. It is recommended that you simply copy HEXLOAD.EXE and the Cygnus firmware to your desktop folder. The HEXLOAD PC software and Cygnus firmware may be in a compressed or ZIP format. You may need to download an additional application such as WinZip from <http://www.winzip.com> to extract the files.

Connection Procedure

1. Turn off the AC power to the Cygnus Web Tension Control.
2. Connect the RS-232 adapter to the Cygnus Web Tension Control.
3. Use the RS-232 cable to connect the cable adapter to a free serial port on the PC.

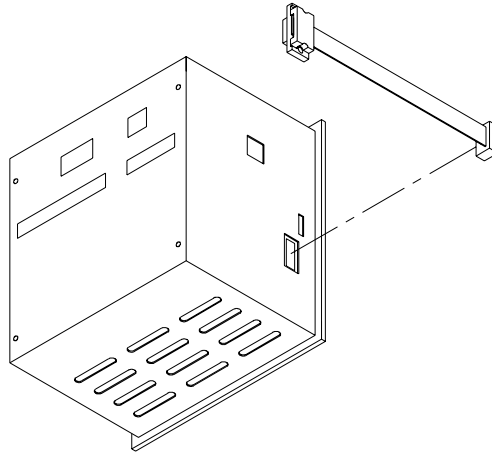
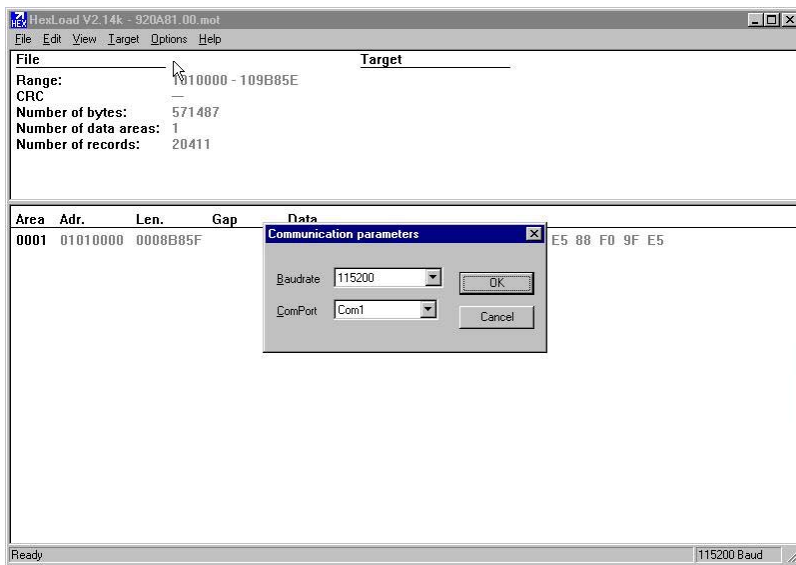

Figure 1
Cygnus with Adapter Cable Installed

Cygnus Flash Programming Procedure

Set the Communications Parameters – Set the communications parameters by selecting the Options/Communications dialog. Set the Baudrate to 115200 baud and the ComPort to the correct port. “Auto” should work for most applications.



Open the firmware/hex file – Open the Cygnus hex file with the HEXLOAD program, by selecting the File/Open dialog and browsing for the correct filename.

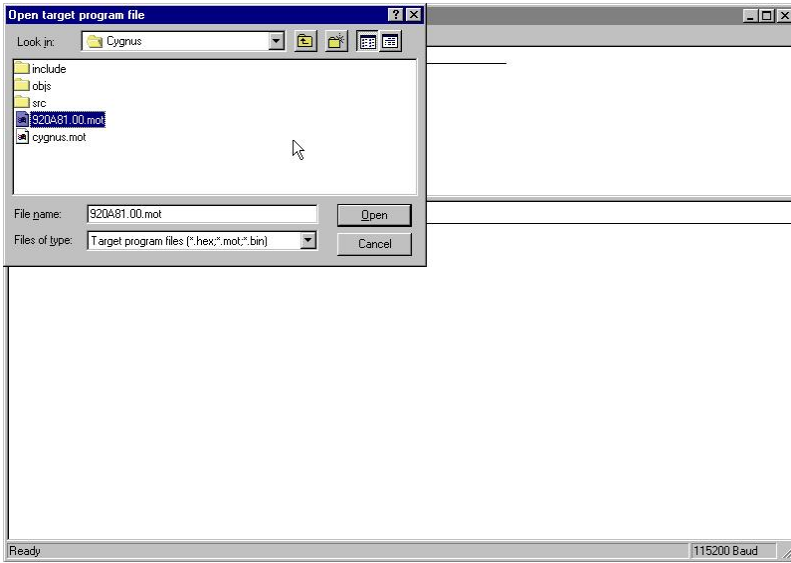

Turn on the AC Power to the Cygnus – and the target information will appear, if you are connected properly. If no target information appears, please check all your connections, before trying again. Also verify that your baud rate and communications port are set properly.

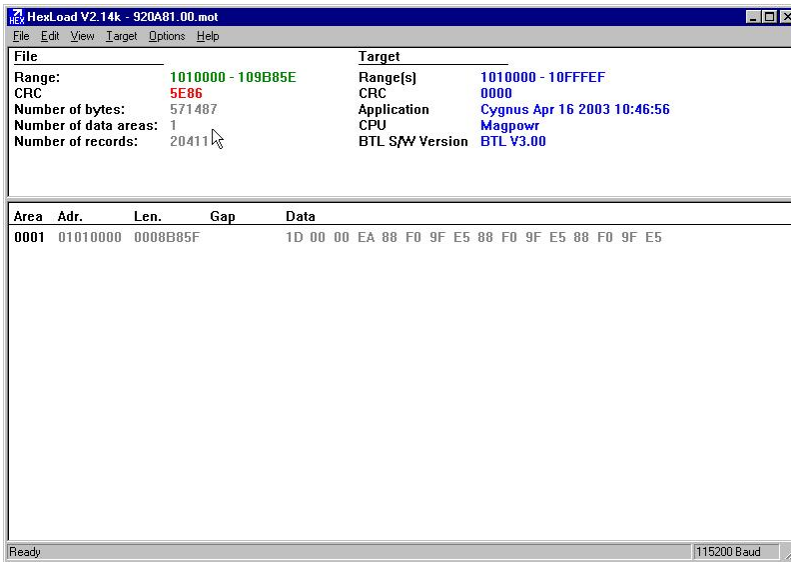

Program the Cygnus Flash Memory – Select the Target/Auto menu option to begin the programming sequence.. The HEXLOAD program automatically sequences through the steps required to program and verify the Flash memory. The programming process takes approximately 2 minutes to complete.

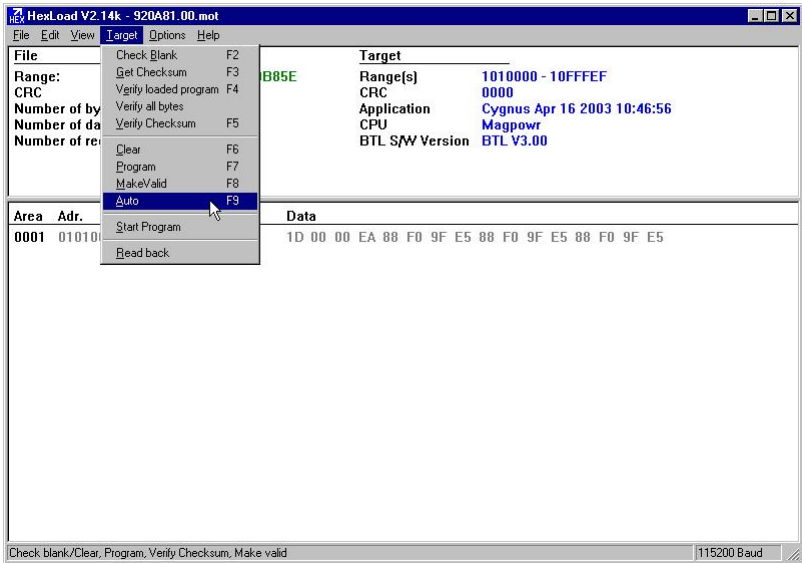

Clearing or Erasing the Flash Memory

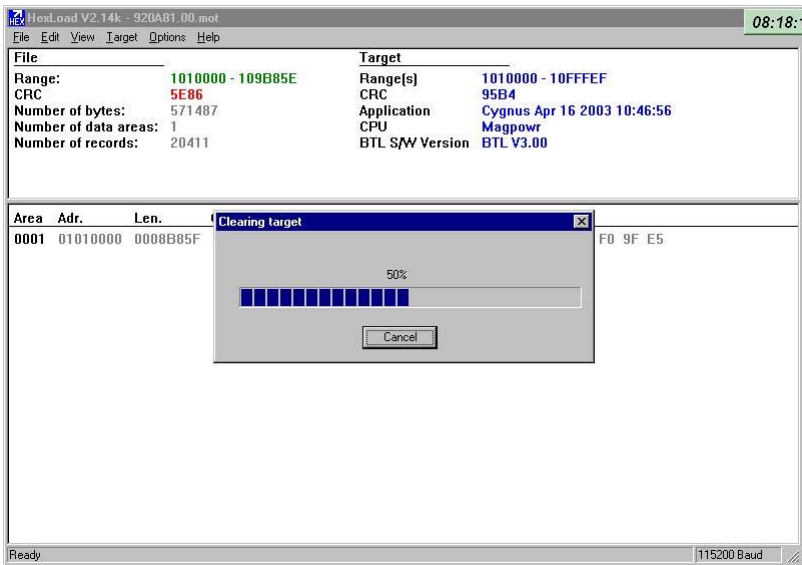

Programming the Flash Memory

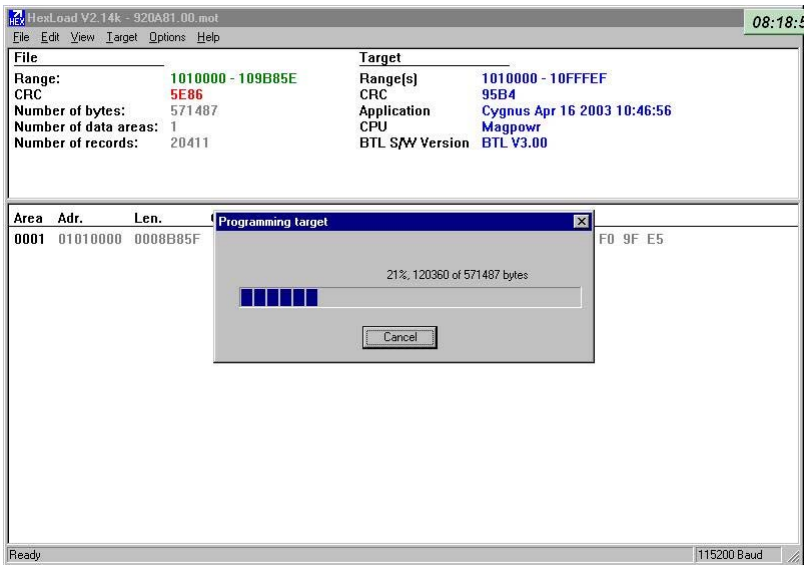

Reading the Checksum or CRC (Cyclic Redundancy Check)

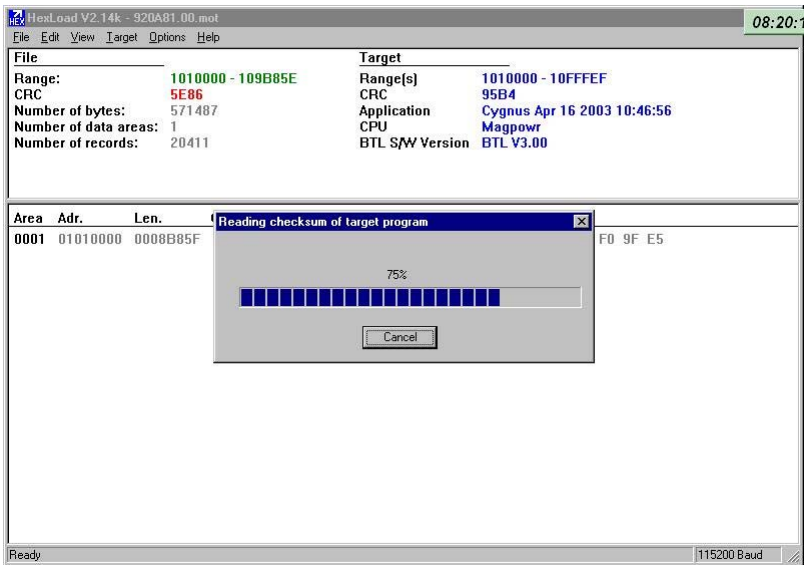

Making the Target Valid

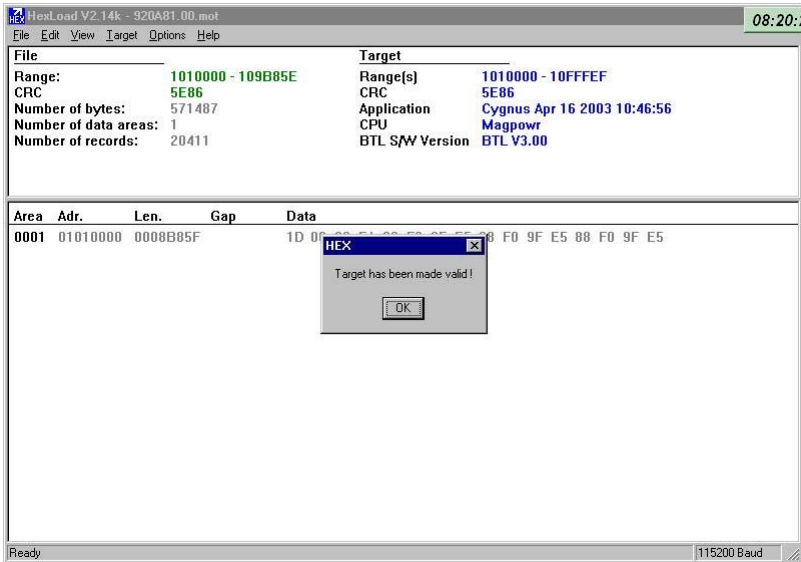

Start the Cygnus Application Software – If the checksum or CRC, from the file and target sections match, you can use the Target/Start Program menu item to start the Cygnus application for the first time. Also, you can exit the HEXLOAD program and cycle the AC power to the Cygnus. If the checksum did not match, repeat the programming process a second time. If the checksum still does not match after a second programming attempt Contact the factory for further assistance since the program has not properly installed.

